



**SYKES**

PUMP SPECIFICATION SHEET

▶ **XH100-560-PR**



# Built Tough

**EXTRA HIGH HEAD PR**



Mining &  
Quarries



Construction  
& Civil



Rental



Industrial



Oil & Gas

▶ **HEAVY  
DUTY**

Automatic self-priming  
single stage end  
suction pump

▶ **SOLIDS  
HANDLING**

Large solids capacity  
while maintaining  
hydraulic efficiencies

▶ **CORROSION  
RESISTANT**

Stainless steel 316  
(CF8M) internals  
as standard

## DESIGN DETAILS

Auto self-priming, centrifugal single stage, end-suction, 5 vane closed impeller.

### PRODUCT SPECIFICATIONS

Suction Flange	150mm [6"]
Delivery Flange	100mm [4"]
Solids Handling	22mm [0.86"]
Maximum Head	182m [597ft]
Maximum Flow	82L/sec [1,300 USgal/min]
Engine Type	Perkins 1106D-E70TA 186kW
Engine Adaptor	SAE #1
Shaft Diameter*	90mm [3.54"]
Fuel Rate @ BEP 1,600rpm**	29.6L/hr [0.13 USgal/min]
Fuel Tank Capacity	2,100L [554 USgal]

\* The nominated shaft diameter is the critical working diameter of the shaft, used for calculation of the shaft stiffness ratio L3/D4.

\*\* Based on standard engine brake specific fuel consumption.

### PREMIUM RANGE (PR) INCLUSIONS

- Structural Steel base.
- Galvanised steel, two-point lifting frame complete with engine canopy.
- Manual diesel fuel fill (lockable).
- Pump and engine control panel with emergency stop as standard.
- Heavy duty battery with battery box enclosure.
- Vacuum (suction inlet) and pressure (discharge outlet) gauges.
- Pump operating range sign for optimum pump life and reliability.
- Galvanised steel sled, complete with tyne pockets and tie down points for transportation.
- Safety inclusions such as heat shields, work lights, lockable battery isolator and fire extinguisher.
- Rear discharge pipe work, complete with geared butterfly valve.

### MATERIALS OF CONSTRUCTION

PART	MATERIAL	MATERIAL STANDARDS			
		GRADE	AS	GRADE	ASTM
Tee Piece	SG Iron	400/12	1831	65-45-12	A536
Front Adaptor Plate	SG Iron	370/17	1831	60-40-18	A536
Pump Casing (Volute)	SG Iron	370/17	1831	60-40-18	A536
Front Wear Plate	Stainless	316/H6B	2074	CF8M	A351
Impeller	Stainless	316/H6B	2074	CF8M	A351
Rear Wear Plate	Stainless	316/H6B	2074	CF8M	A351
Rear Adaptor Plate	SG Iron	370/17	1831	60-40-18	A536
Pump Shaft	Stainless	431	2074	98b-431	A276
Bearing Bracket	SG Iron	400/12	1831	65-45-12	A536
Bearing Covers	SG Iron	400/12	1831	65-45-12	A536
Mechanical Seal†	Multi-spring balanced cartridge type				

† Multi-spring balanced double hard faced cartridge type mechanical seal complete with oil lubrication and pumping ring. Seal faces are silicon carbide vs. tungsten carbide.

### OPTIONAL EXTRAS

Please contact us to discuss these options:

- Additional operational, mobility and safety extras such as: suction and discharge couplings, strainers, double skin fuel tanks and trailers. These can all be selected and fitted to our Premium Range (PR) pump units.
- Our PR build configuration uses Caterpillar® diesel engines, however, alternative engine brands are available upon request.
- Other pump materials of construction are also available upon request: full 316 stainless steel, CD4MCU, chromium steel, SAF 2205 and SAF 2507.

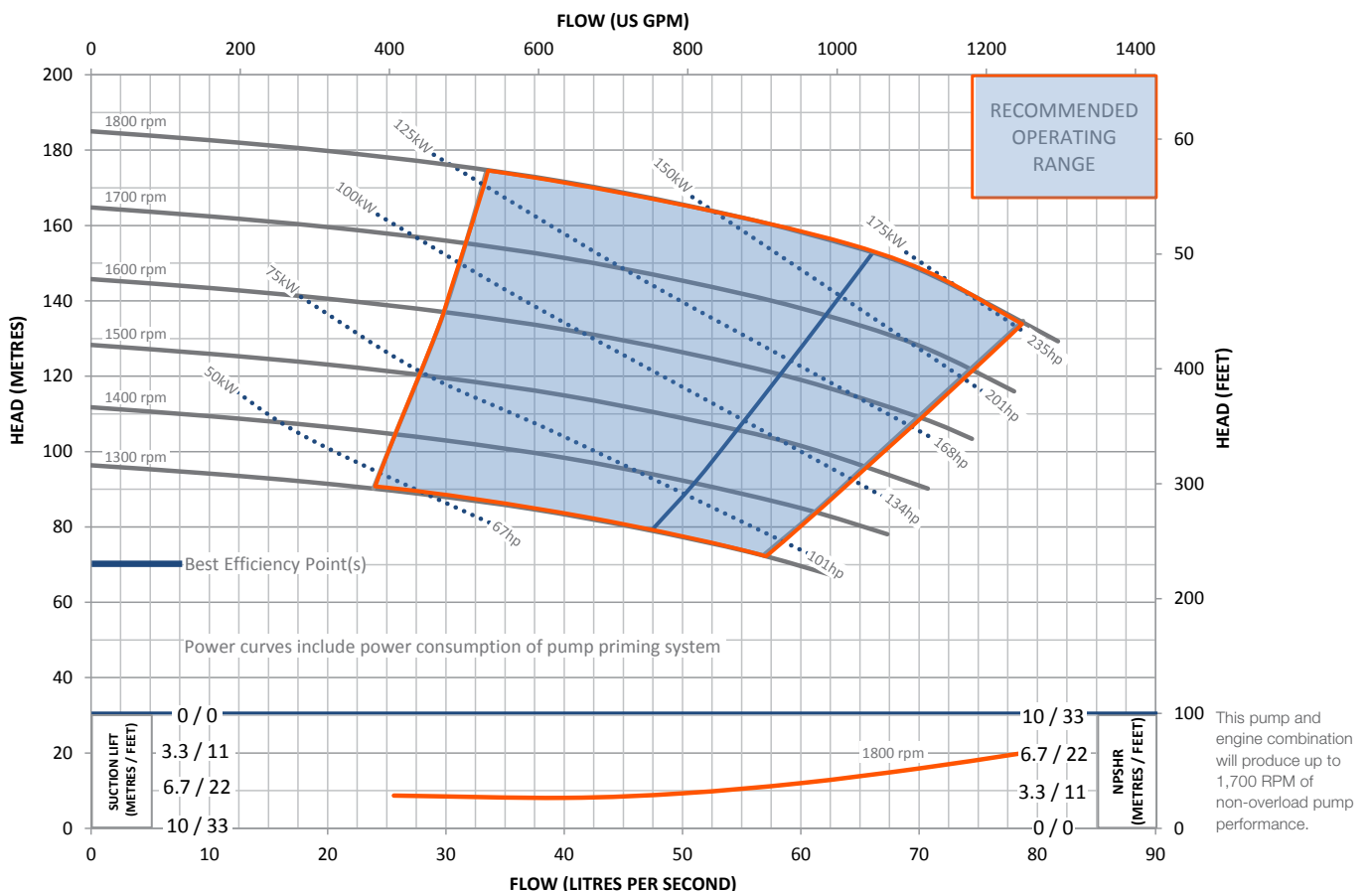

This pump and engine combination will produce up to 1,700 RPM of non-overload pump performance.

# TECHNICAL DATA

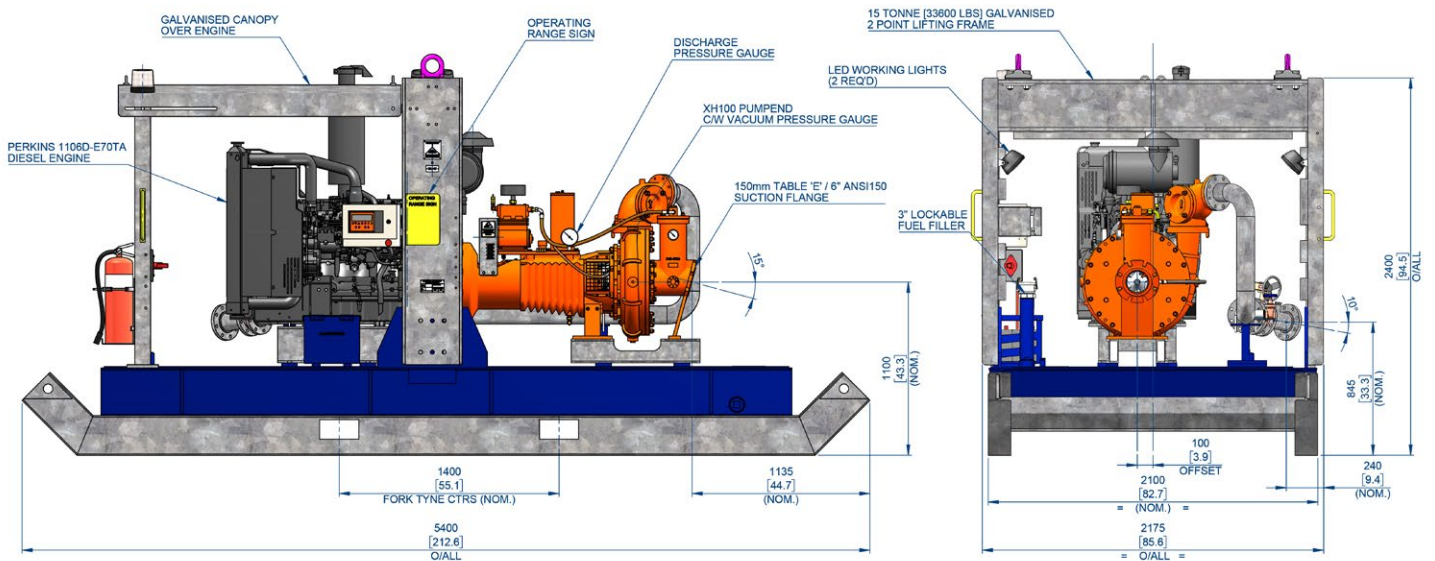

DRY: 5,520kg [12,169 lb]

WET: 7,260kg [16,005 lb]

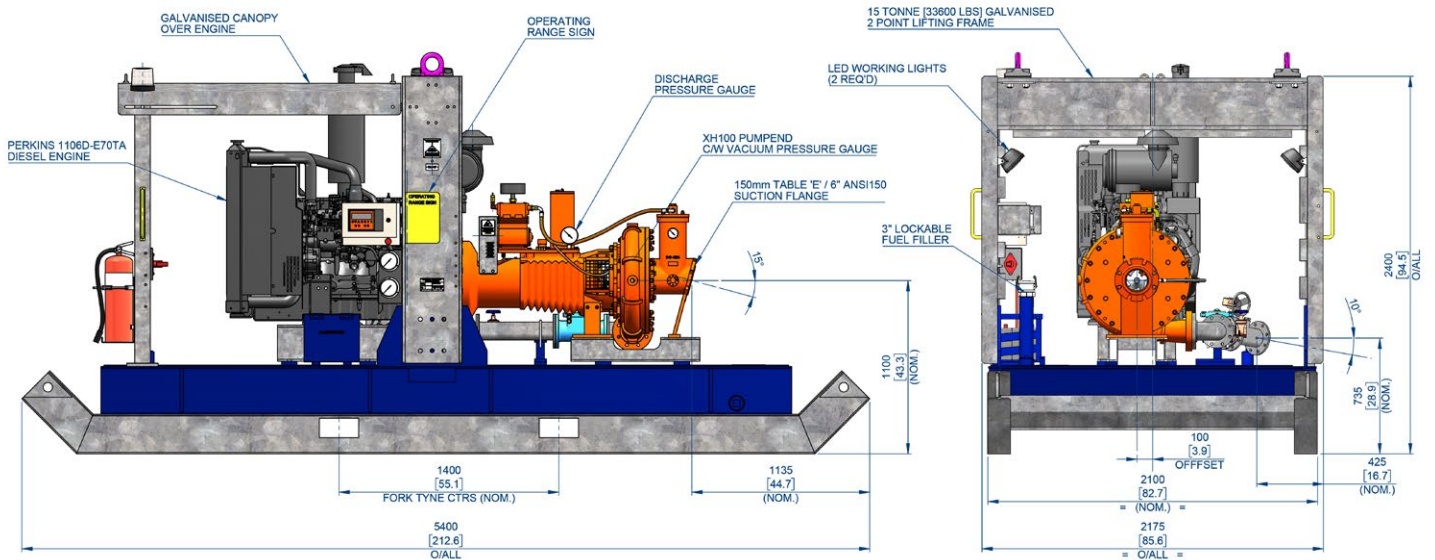

DRY: 4,572kg [10,079 lb]

WET: 6,312kg [13,915 lb]

**Note:** Final weight and dimensions will depend on completed specifications and options, subject to manufacturing tolerances. All the information in this document is substantially correct at the time of creation and may be altered at the manufacturer's sole discretion. Any quotes and related material provided supersedes the contents hereof.

Copyright © 2023, 2024 Sykes Group Pty Ltd. All rights reserved. Sykes is a trademark and or registered trademark of Sykes Group Pty Ltd.

[www.sykesgroup.com](http://www.sykesgroup.com)