



# Built Tough

## SEWAGE & WASTE PR

### HEAVY DUTY

Automatic self-priming single stage end suction pump

### SOLIDS HANDLING

Large solids capacity while maintaining hydraulic efficiencies

### CORROSION RESISTANT

Stainless steel 316 (CF8M) internals as standard.



Construction & Civil



Sewage & Waste Water



Rental



Industrial



Marine

**DESIGN DETAILS**

Auto self priming, centrifugal single stage, end suction, 2 vane semi open impeller

Suction Flange	100mm / 4"
Delivery Flange	100mm / 4"
Solids Handling	76mm / 2.99"
Maximum Head	53m / 174ft
Maximum Flow	77L/sec / 1,220 USgal/min
Engine Type	Perkins 404D-22T
Engine Adaptor	SAE #4
Shaft Diameter	40mm / 1.57"
Fuel Rate @ BEP 2,000rpm	6.1L/hr / 0.03 USgal/min *
Fuel Rate @ BEP 1,600rpm	3.8L/hr / 0.02 USgal/min *
Fuel Tank Capacity	250L / 66 USgal

**PREMIUM RANGE (PR) INCLUSIONS**

- Structural Steel base.
- Galvanised steel, two-point lifting frame complete with engine canopy.
- Manual diesel fuel fill (lockable).
- Pump and engine control panel with emergency stop as standard.
- Heavy duty battery with battery box enclosure.
- Vacuum (suction inlet) and Pressure (discharge outlet) gauges.
- Pump operating range sign for optimum pump life and reliability.
- Galvanised steel sled, complete with tyne pockets and tie down points for transportation.
- Safety inclusions such as heat shields, work lights, lockable battery isolator and fire extinguisher.
- Rear discharge pipe work, complete with geared butterfly valve.

**MATERIALS OF CONSTRUCTION**

STANDARDS	MATERIAL	AUSTRALIA		AMERICAS	
		GRADE	AS	GRADE	ASTM
Tee Piece	SG Iron	400/12	1831	65-45-12	A536
Pump Casing (Volute)	SG Iron	400/12	1831	65-45-12	A536
Front Wear Plate	Stainless	316/H6B	2074	CF8M	A351
Impeller	Stainless	316/H6B	2074	CF8M	A351
Rear Wear Plate	Stainless	316/H6B	2074	CF8M	A351
Pump Shaft	Stainless	431	2074	98b-431	A276
Bearing Bracket	SG Iron	400/12	1831	65-45-12	A536
Bearing Covers	SG Iron	400/12	1831	65-45-12	A536
Mechanical Seal	Multi spring balanced mechanical seal assembly with silicon carbide/silicon carbide mechanical seal faces in self-contained oil reservoir.				

**OPTIONAL EXTRAS**

Please contact us to discuss these options:

- Additional operational, mobility and safety extras such as: suction and discharge couplings, strainers, double skin fuel tanks and trailers. These can all be selected and fitted to our Premium Range (PR) pump units.
- Our PR build configuration uses Perkins diesel engines, however, alternative engine brands are available upon request.
- Other pump materials of construction are also available upon request: full 316 stainless steel, CD4MCU, chromium steel, SAF 2205 and SAF 2507.

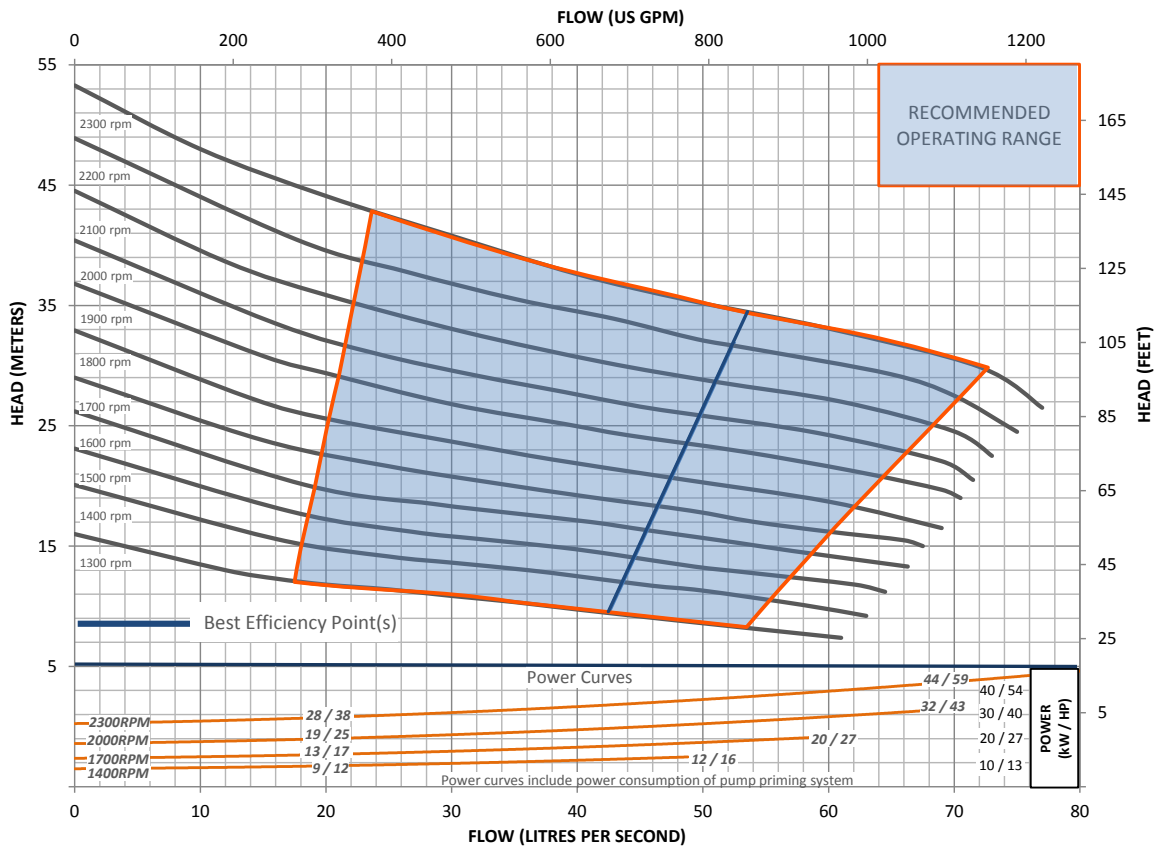

This pump and engine combination will produce up to 2,100 RPM of non-overload pump performance.

\* Based on standard engine brake specific fuel consumption.

Final weight and dimensions will depend on completed specifications and options, subject to manufacturing tolerances. All the information in this document is substantially correct at the time of creation and may be altered at the manufacturer's sole discretion. Any quotes and related material provided supersedes the contents hereof.

# TECHNICAL DATA

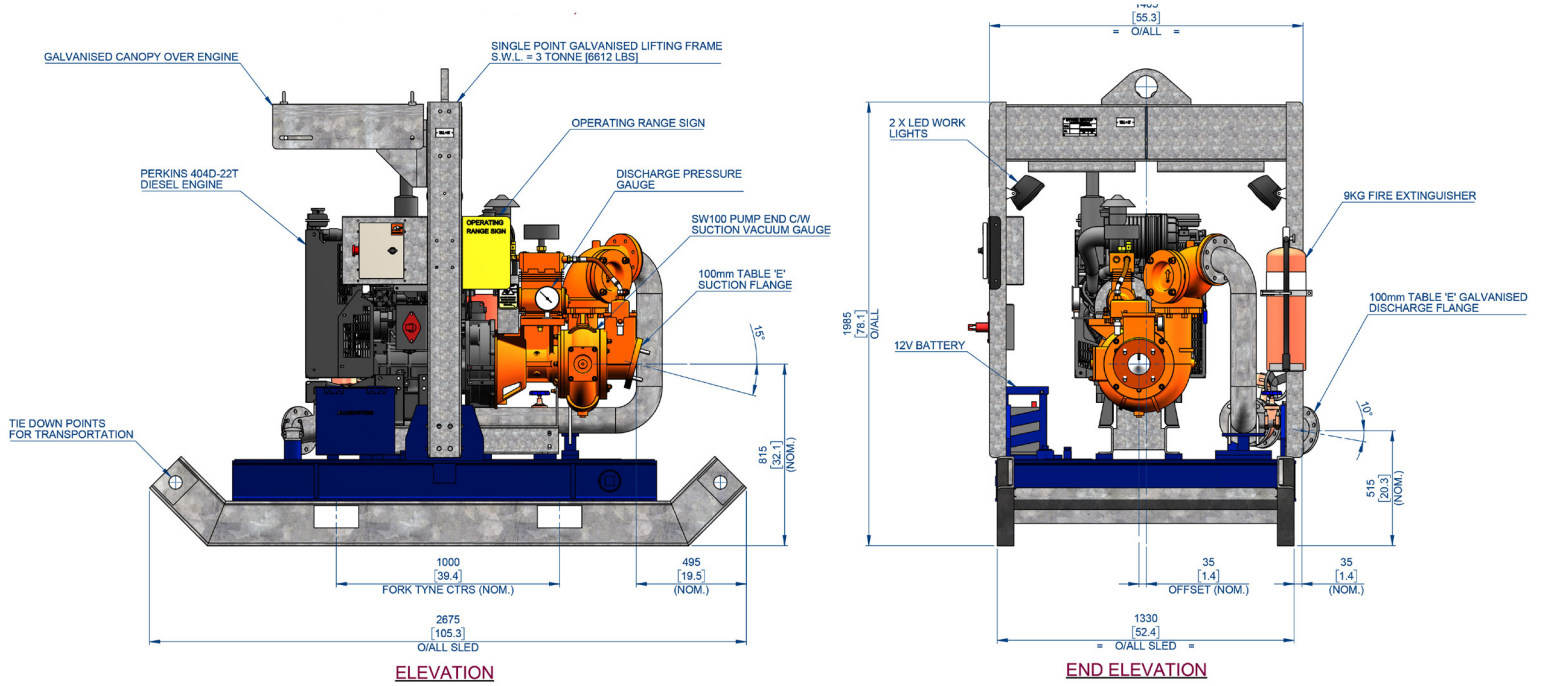

DRY: 1,533 kg (3,379 lb)

WET: 1,740 kg (3,836 lb)

\* Based on standard engine brake specific fuel consumption.

\*\*Average measurement over 30 seconds in an open, non reflective environment.

Final weight and dimensions will depend on completed specifications and options, subject to manufacturing tolerances. All the information in this document is substantially correct at the time of creation and may be altered at the manufacturer's sole discretion. Any quotes and related material provided supersedes the contents hereof.