



Built Tough

CONTRACTOR PUMP YAKKA 80

HEAVY DUTY

Automatic self-priming single stage end suction pump

SOLIDS HANDLING

Large solids capacity while maintaining hydraulic efficiencies

CORROSION RESISTANT

Stainless steel 316 (CF8M) internals as standard.



Construction & Civil



Quarries



Rental



Agriculture



DESIGN DETAILS

Auto self priming, centrifugal single stage, end suction, 2 vane semi open impeller

Suction Flange	100mm / 4"
Delivery Flange	100mm / 4"
Solids Handling	25mm / 1"
Maximum Head	107m / 351ft
Maximum Flow	29L/sec / 460USgal/min
Engine Type	Perkins 404D-22T
Engine Adaptor	SAE #4
Shaft Diameter	40mm / 1.57"
Fuel Rate @ BEP 1,950rpm	8.2L/hr / 0.04 USgal/min *
Fuel Rate @ BEP 1,600rpm	4.0L/hr / 0.02 USgal/min *
Fuel Tank Capacity	250L / 66 USgal

MATERIALS OF CONSTRUCTION

STANDARDS	MATERIAL	AUSTRALIA		AMERICAS	
		GRADE	AS	GRADE	ASTM
Tee Piece	SG Iron	400/12	1831	65-45-12	A536
Pump Casing (Volute)	SG Iron	400/12	1831	65-45-12	A536
Front Wear Plate	Stainless	316/H6B	2074	CF8M	A351
Impeller	Stainless	316/H6B	2074	CF8M	A351
Rear Wear Plate	Stainless	316/H6B	2074	CF8M	A351
Pump Shaft	Stainless	431	2074	98b-431	A276
Bearing Bracket	SG Iron	400/12	1831	65-45-12	A536
Bearing Covers	SG Iron	400/12	1831	65-45-12	A536
Mechanical Seal	Multi spring balanced mechanical seal assembly with silicon carbide/silicon carbide mechanical seal faces in self-contained oil reservoir.				

OPTIONAL EXTRAS

Please contact us to discuss these options:

- Additional operational, mobility and safety extras, such as: suction and discharge couplings, strainers, and battery isolators. These can all be selected and fitted to our Yakka Range pump units.
- Other pump materials of construction are also available upon request: full 316 stainless steel, CD4MCU, chromium steel, SAF 2205 and SAF 2507.

YAKKA RANGE INCLUSIONS

- Heavy single-point lifting frame.
- Manual diesel fuel fill (lockable).
- Pump and engine control panel with emergency stop as standard. Mounted externally.
- Heavy duty battery.
- Bunded fuel tank.
- Single axle trailer for improved maneuverability.
- Externally mounted fire extinguisher.
- Remote, externally-mounted vacuum (suction inlet) and pressure (discharge outlet) gauges.

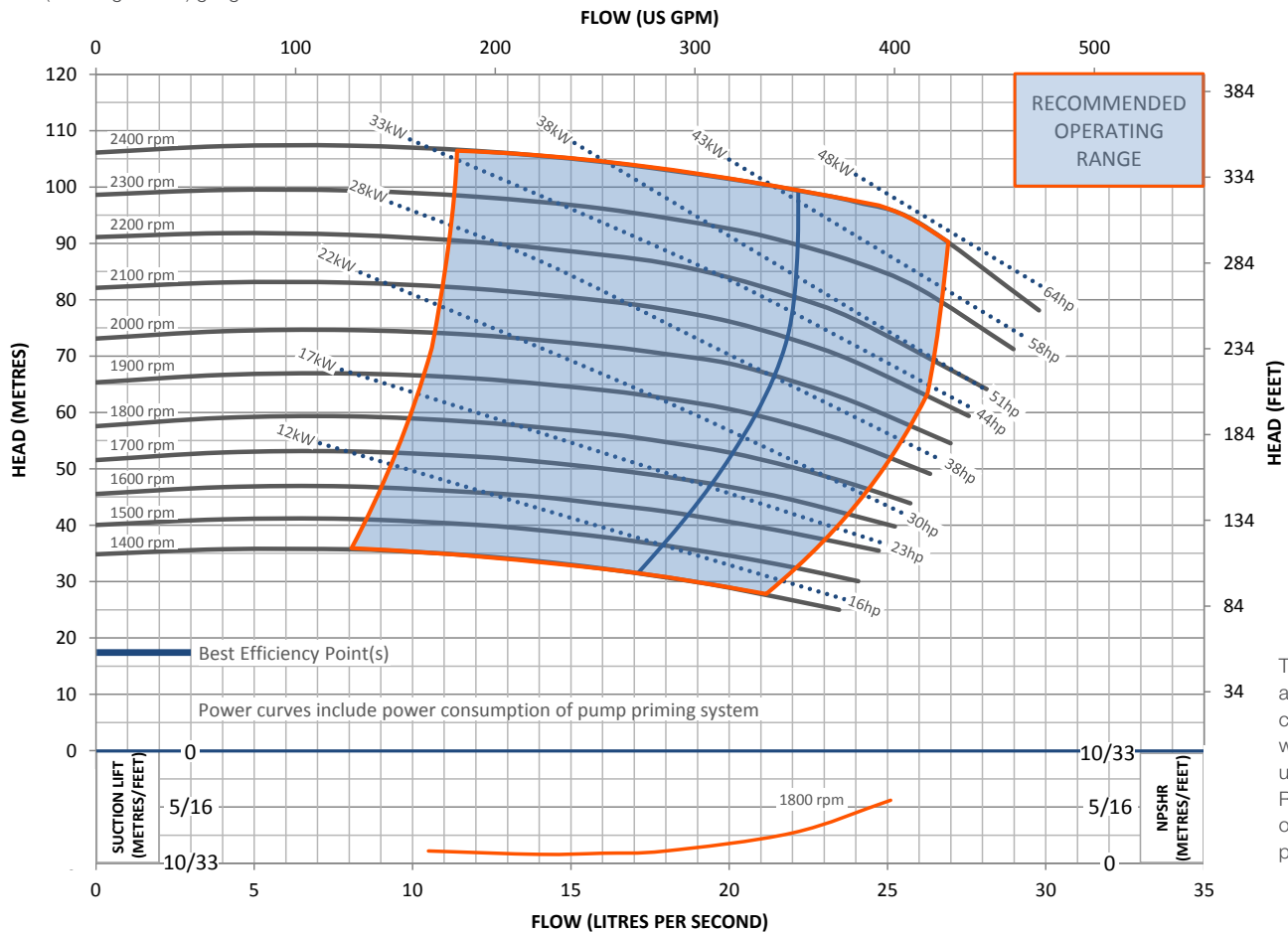

This pump and engine combination will produce up to 2100 RPM of non-overload pump performance.

* Based on standard engine brake specific fuel consumption.

Final weight and dimensions will depend on completed specifications and options, subject to manufacturing tolerances. All the information in this document is substantially correct at the time of creation and may be altered at the manufacturer's sole discretion. Any quotes and related material provided supersedes the contents hereof.

TECHNICAL DATA

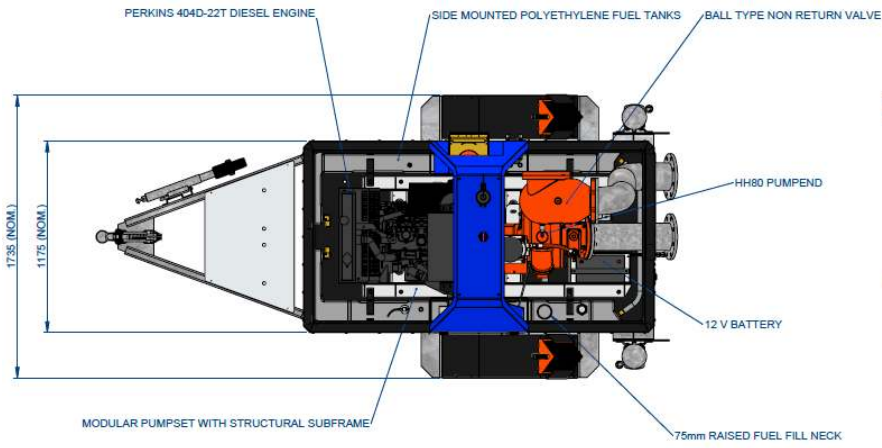

PLAN
(CANOPY REMOVED FOR CLARITY)

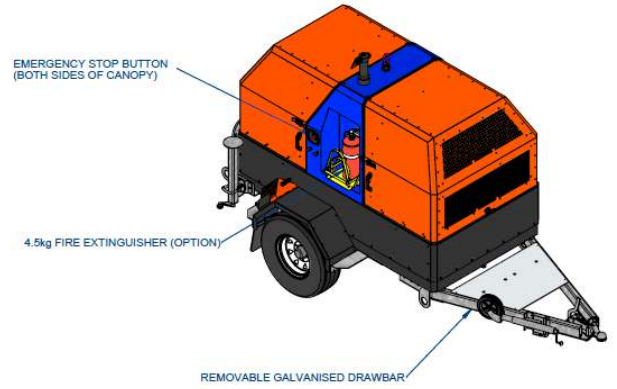

ISOMETRIC

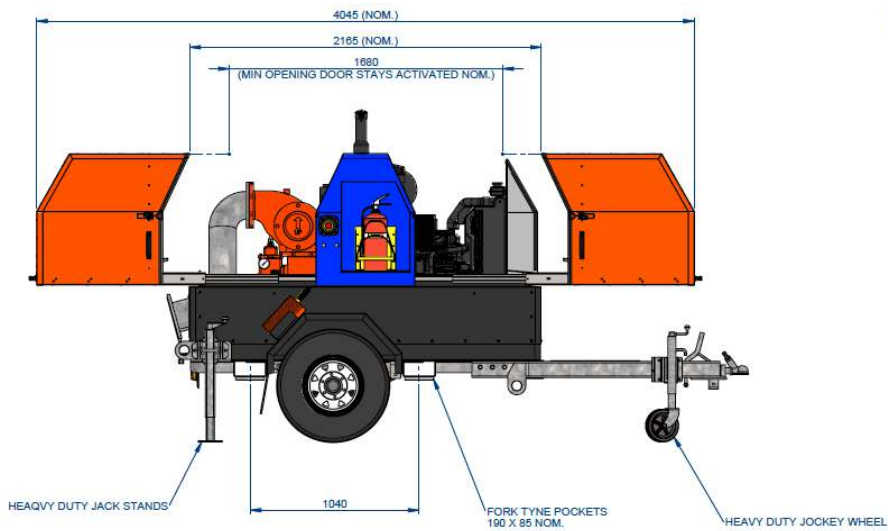

REAR ELEVATION
(CANOPY OPEN)

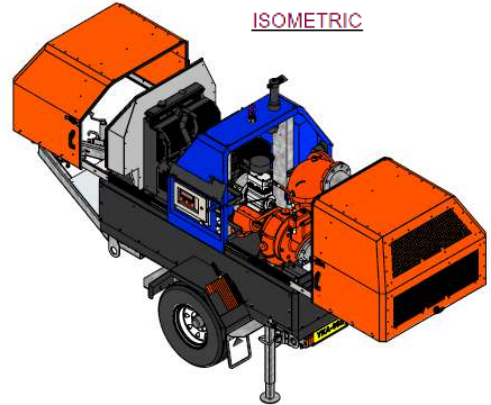

ISOMETRIC
(CANOPY OPEN)

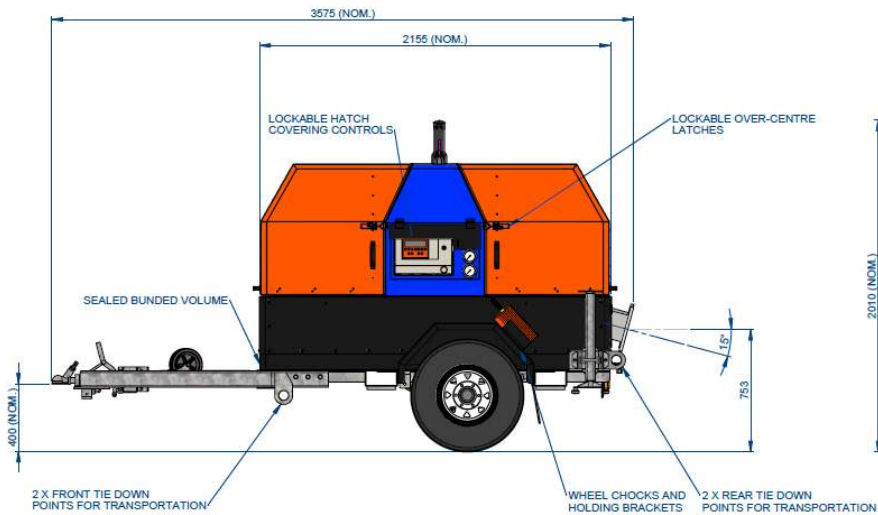
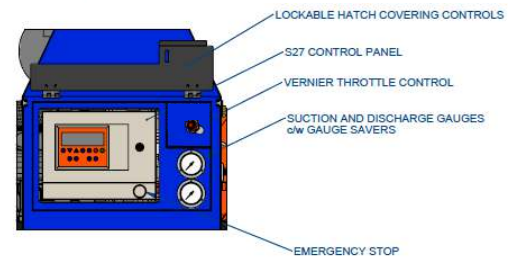

FRONT ELEVATION

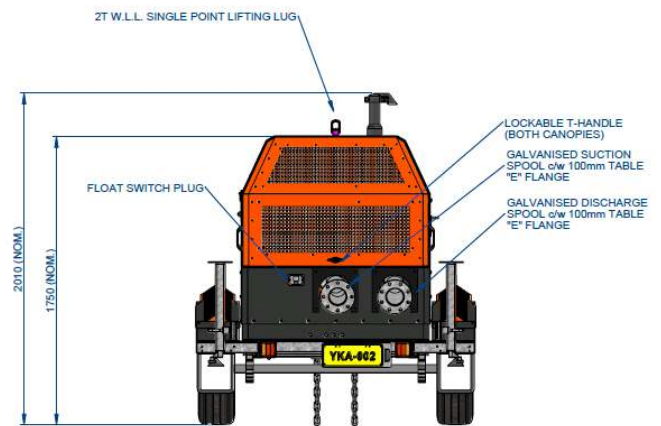

END ELEVATION

DRY: 1,615 kg (3,560 lb)

WET: 1,815 kg (4,001 lb)

* Based on standard engine brake specific fuel consumption.

Final weight and dimensions will depend on completed specifications and options, subject to manufacturing tolerances. All the information in this document is substantially correct at the time of creation and may be altered at the manufacturer's sole discretion. Any quotes and related material provided supersedes the contents hereof.