



Built Tough

CONTRACTOR PUMP BR

HEAVY DUTY

Automatic self-priming single stage end suction pump

SOLIDS HANDLING

Large solids capacity while maintaining hydraulic efficiencies

CORROSION RESISTANT

Stainless steel 316 (CF8M) internals as standard.



Construction & Civil



Quarries



Rental



Agriculture

DESIGN DETAILS

Auto self priming, centrifugal single stage, end suction, 2 vane semi open impeller

Suction Flange	150mm / 6"
Delivery Flange	150mm / 6"
Solids Handling	77mm / 3.03"
Maximum Head	43m / 141ft
Maximum Flow	163L/sec / 2,584 USgal/min
Engine Type	Perkins 404D-22
Engine Adaptor	SAE #4
Shaft Diameter	40mm / 1.57"
Fuel Rate @ BEP 2,000rpm	8.4L/hr / 0.04 USgal/min *
Fuel Rate @ BEP 1,600rpm	4.0L/hr / 0.02 USgal/min *
Fuel Tank Capacity	80L / 21 USgal

BASIC RANGE (BR) INCLUSIONS

- Galvanised, folded steel base, complete with fork tyne pockets and a single point lifting frame.
- Manual diesel fuel fill (lockable).
- Pump and engine control panel with emergency stop as standard.
- Heavy duty battery.

MATERIALS OF CONSTRUCTION

STANDARDS	MATERIAL	AUSTRALIA		AMERICAS	
		GRADE	AS	GRADE	ASTM
Tee Piece	SG Iron	400/12	1831	65-45-12	A536
Pump Casing (Volute)	SG Iron	400/12	1831	65-45-12	A536
Front Wear Plate	Stainless	316/H6B	2074	CF8M	A351
Impeller	Stainless	316/H6B	2074	CF8M	A351
Rear Wear Plate	Stainless	316/H6B	2074	CF8M	A351
Pump Shaft	Stainless	431	2074	98b-431	A276
Bearing Bracket	SG Iron	400/12	1831	65-45-12	A536
Bearing Covers	SG Iron	400/12	1831	65-45-12	A536
Mechanical Seal	Multi spring balanced mechanical seal assembly with silicon carbide/silicon carbide mechanical seal faces in self-contained oil reservoir.				

OPTIONAL EXTRAS

Please contact us to discuss these options:

- Additional operational, mobility and safety extras such as: suction and discharge couplings, strainers, battery isolators, sleds and trailers. These can all be selected and fitted to our Basic Range (BR) pump units.
- Our BR build configuration uses Perkins diesel engines, however, alternative engine brands are available upon request.
- Other pump materials of construction are also available upon request: full 316 stainless steel, CD4MCU, chromium steel, SAF 2205 and SAF 2507.

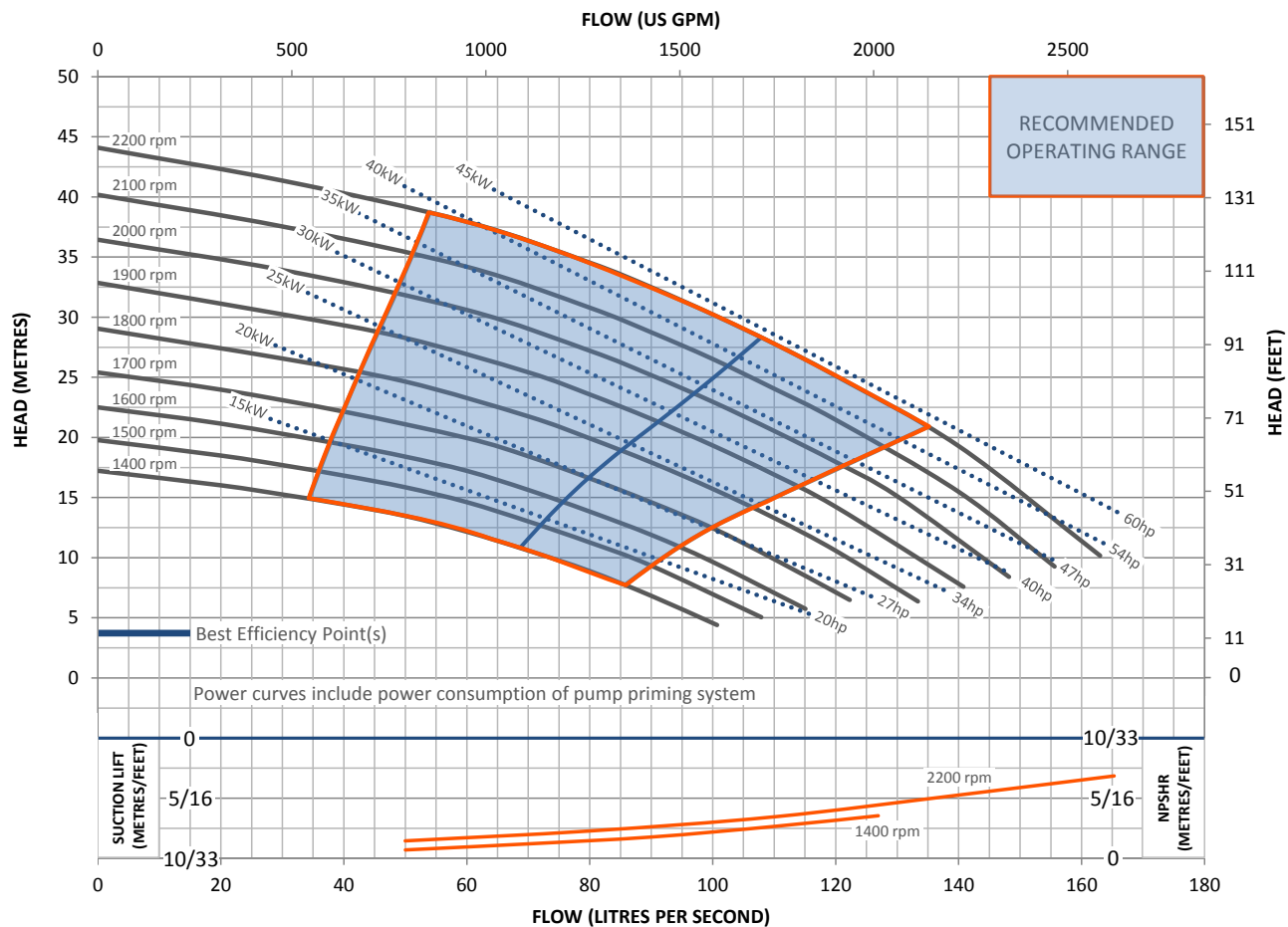

This pump and engine combination will produce up to 1,700 RPM of non-overload pump performance.

* Based on standard engine brake specific fuel consumption.

Final weight and dimensions will depend on completed specifications and options, subject to manufacturing tolerances. All the information in this document is substantially correct at the time of creation and may be altered at the manufacturer's sole discretion. Any quotes and related material provided supersedes the contents hereof.

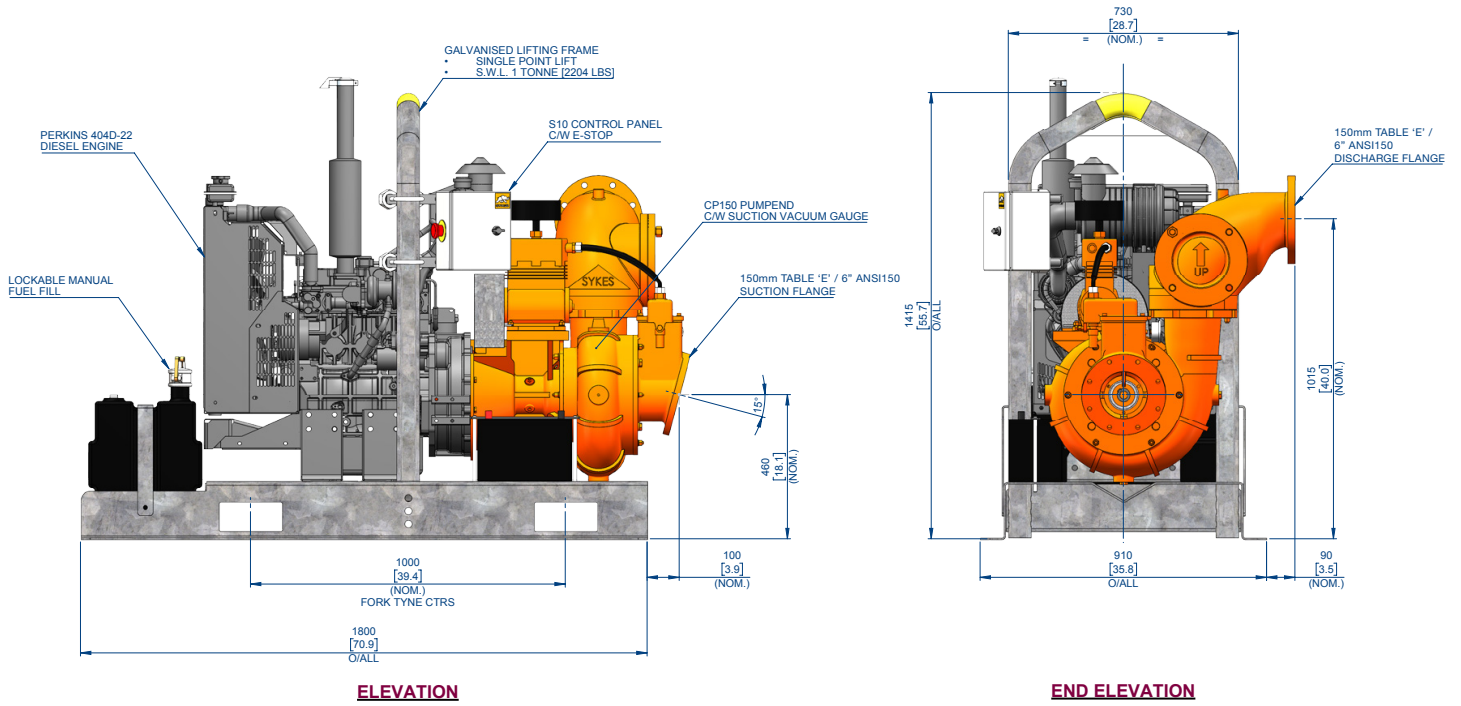

DRY: 771 kg (1,700 lb)

WET: 837 kg (1,845 lb)

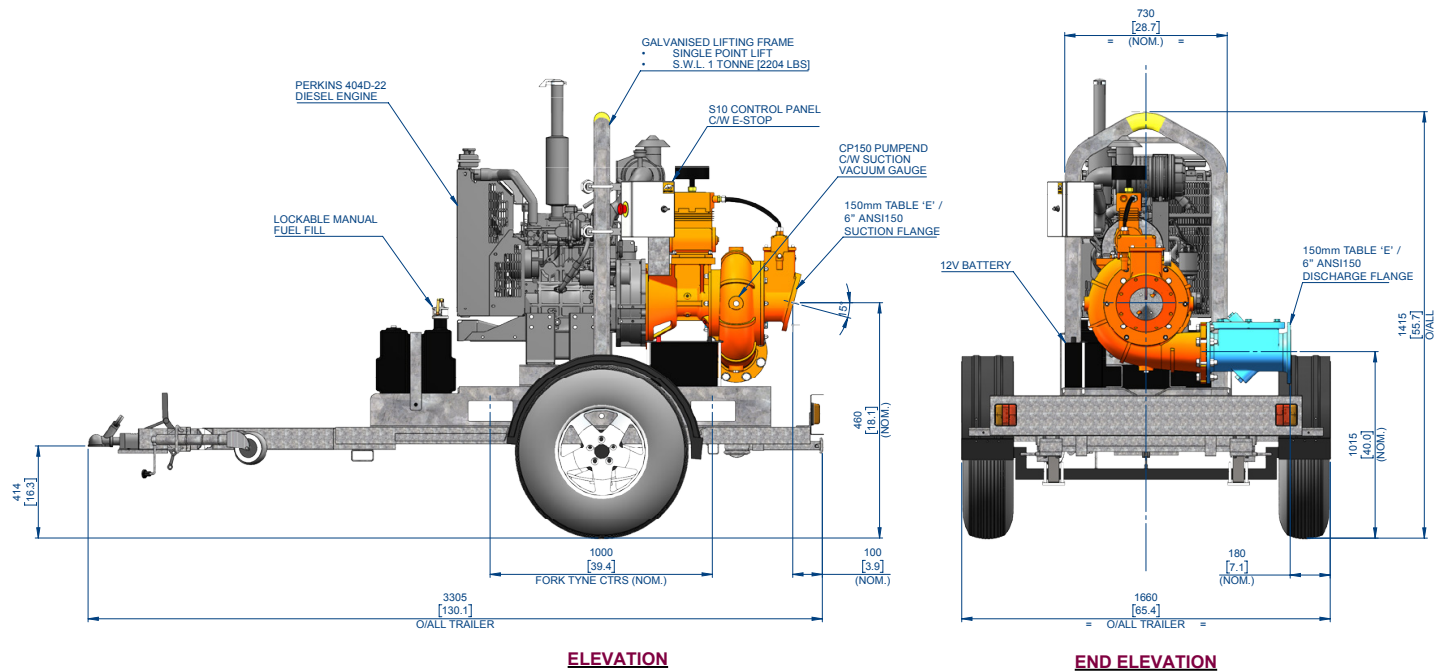

DRY: 1,009 kg (2,225 lb)

WET: 1,075 kg (2,370 lb)

* Based on standard engine brake specific fuel consumption.

Final weight and dimensions will depend on completed specifications and options, subject to manufacturing tolerances. All the information in this document is substantially correct at the time of creation and may be altered at the manufacturer's sole discretion. Any quotes and related material provided supersedes the contents hereof.