

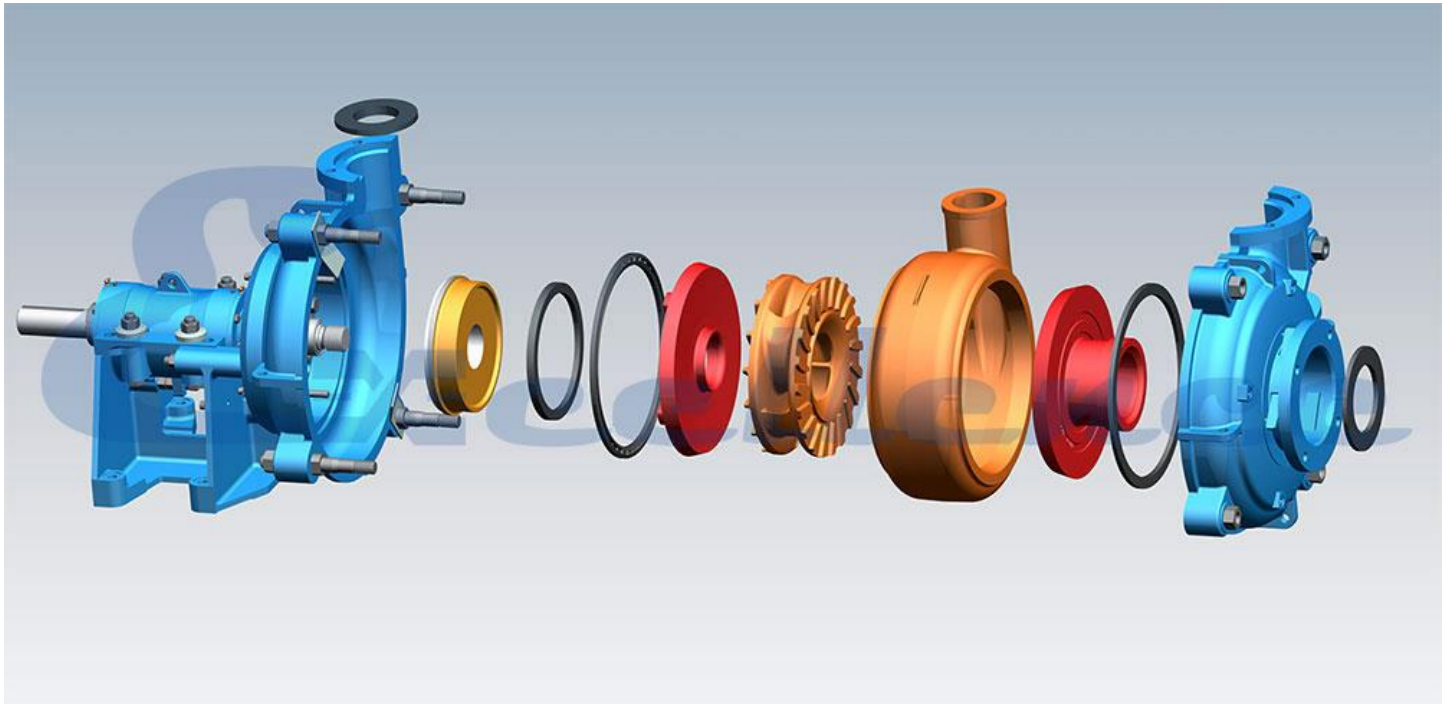

Designed for handling light abrasive and low concentration slurries, ELM series slurry pumps are cantilevered light duty slurry pumps with metal liner.



- Cylindrical structure of bearing assembly: convenient to adjust the space between impeller and Throatbush and can be removed completely;
- Interchangeable anti-abrasive wet parts made of high-chrome alloys;
- The discharge direction can be oriented to any eight positions at the interval of 45 degrees;
- Various drive types: DC(direct connection), V-belt drive, gear box reducer, hydraulic couplings, VFD, SCR control, etc;
- The shaft seal can be packing seal, expeller seal or mechanical seal;
- High efficiency, long lifetime and easy maintenance.

## ❖ Structure

### Series ELM structural drawing:

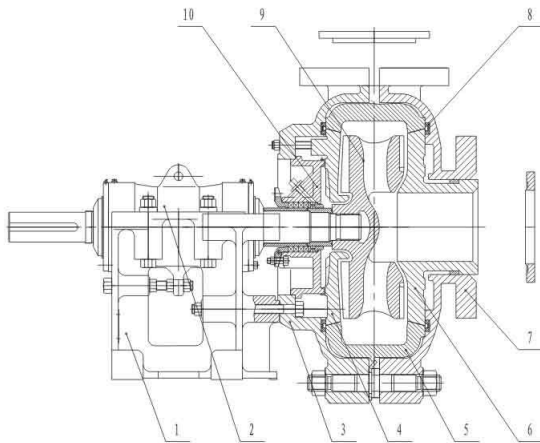

- |                             |                           |
|-----------------------------|---------------------------|
| 1. Frame                    | 6. Throatbush             |
| 2. Bearing assembly         | 7. Cover plate            |
| 3. Frame plate              | 8. Volute liner seal ring |
| 4. Frame plate liner insert | 9. Impeller               |
| 5. Volute liner             | 10. Stuffing box          |

Note: this is the basic drawing of structure. There would be some differences up to varied discharge size.



ELM-350S

### Bearing Assembly

Convenient to adjust the space between impeller and front liner and can be removed completely;

- Lubricated by grease;
- Easy maintenance;

### Shaft Seal

There are three standard shaft seal methods:

- Packing seal: it is the lowest in cost.
- Expeller seal: it is most commonly used.
- Mechanical seal: it has best seal effect, but high in cost and has strict requirement of flush water.

### Material

The wet parts material for standard ELM series pump is high-chrome alloy. This kind of material is wear resistant and has excellent performance under erosive conditions.

- KmTBCr27: hard carbides within its microstructure provides strong wear resistance
- KmTBCr28: its hardness is 430 in Brinell and suitable for corrosive applications where pH is below 4.
- KmTBCr35: its hardness is 450 in Brinell and has much improved corrosion resistance.

## ❖ Performance Chart

Model	Allowable Max. Power P(Kw)	Clear Water Performance						Impeller
		Capacity Q		Head H(m)	Speed n(r/min)	Top Efficiency η%	NPSH(m)	Impeller Diameter D(mm)
		m <sup>3</sup> /h	l/s					
ELM-50B	15	11.5-65	3.2-18	8.5-46	1400-2800	62	2.5-5.5	190
ELM-75C	30	21.6-136.8	6-38	7-46.4	900-2400	57	3-6	229
ELM-100D	60	46.8-324	13-90	7-48.30	800-1800	64	2.5-6	305
ELM-150E	120	126-568.80	35-158	10.5-51.8	800-1500	60	2.5-6	381
ELM-300S	560	568-2538	130-705	8-60	400-950	79	2-10	653
ELM-350S	560	650-2800	180-780	10-59	400-840	81	3-10	736
ELM-400ST	560	756-3312	210-920	7-37.5	300-600	85	2-8	825
ELM-450ST	560	1080-4356	300-1210	9-40	300-550	87	3-10	933
ELM-550TU	1200	1980-7920	560-2200	10-50	250-475	86	4-10	1213

## ❖ Application

Series ELM slurry pumps are widely used in mining, coal washing, power plant, metallurgy, petrochemical, building material, dredging, and other industrial fields, etc.

### Typical Application:

- Iron Ore Dressing Plant
- Copper Concentration Plant
- Gold Mine Concentration Plant
- Molybdenum Concentration Plant
- Potash Fertilizer Plant
- Other Mineral Processing Plants
- Alumina Industry
- Coal Washery
- Power Plant
- Sand Excavation
- Building Material Industry
- Chemical Industry
- Other industries



*ELM-100D in Cement Plant in Thailand*



*ELM-350S in Coal Washery in Indonesia*

*ELM-100D in Wastewater Treatment Plant in Italy*



**Headquarter:**

Add: No.399, Yuanshi Avenue, Macun Industrial Park, Shijiazhuang 051130.

**Beijing Branch:**

Add: No.78, East 4th Ring Middle Road, Beijing, China 100124.

Tel: +86-10-59626498

Fax: +86-10-59626499

For inquiries, please send your emails to [sales@excellencepump.com](mailto:sales@excellencepump.com)

For customer service, please send your emails to [service@excellencepump.com](mailto:service@excellencepump.com)