



Built Tough

EXTRA HIGH HEAD PR

HEAVY DUTY

Automatic self-priming single stage end suction pump

SOLIDS HANDLING

Large solids capacity while maintaining hydraulic efficiencies

CORROSION RESISTANT

Stainless steel 316 (CF8M) internals as standard.



Mining



Rental



Oil & Gas

DESIGN DETAILS

Auto self priming, centrifugal single stage, end suction, 5 vane closed impeller

Suction Flange	250mm / 10"
Delivery Flange	200mm / 8"
Solids Handling	31mm / 1.22"
Maximum Head	208m / 682ft
Maximum Flow	230L/sec / 3,646 USgal/min
Engine Type	CAT C-27
Engine Adaptor	SAE #1
Shaft Diameter	90mm / 3.54"
Fuel Rate @ BEP 2,000rpm	N/A
Fuel Rate @ BEP 1,600rpm	98.8L/hr / 0.44 USgal/min *
Fuel Tank Capacity	3,300L / 871 USgal

PREMIUM RANGE (PR) INCLUSIONS

- Structural Steel base.
- Galvanised steel, two-point lifting frame complete with engine canopy.
- Manual diesel fuel fill (lockable).
- Pump and engine control panel with emergency stop as standard.
- Heavy duty battery with battery box enclosure.
- Vacuum (suction inlet) and Pressure (discharge outlet) gauges.
- Pump operating range sign for optimum pump life and reliability.
- Galvanised steel sled, complete with tyre pockets and tie down points for transportation.
- Safety inclusions such as heat shields, work lights, lockable battery isolator and fire extinguisher.
- Rear discharge pipe work, complete with geared butterfly valve.

MATERIALS OF CONSTRUCTION

STANDARDS	MATERIAL	AUSTRALIA		AMERICAS	
		GRADE	AS	GRADE	ASTM
Tee Piece	SG Iron	400/12	1831	65-45-12	A536
Front Adaptor Plate	SG Iron	370/17	1831	60-40-18	A536
Pump Casing (Volute)	SG Iron	370/17	1831	60-40-18	A536
Front Wear Plate	Stainless	316/H6B	2074	CF8M	A351
Impeller	Stainless	316/H6B	2074	CF8M	A351
Rear Wear Plate	Stainless	316/H6B	2074	CF8M	A351
Rear Adaptor Plate	SG Iron	370/17	1831	60-40-18	A536
Pump Shaft	Stainless	431	2074	98b-431	A276
Bearing Bracket	SG Iron	400/12	1831	65-45-12	A536
Bearing Covers	SG Iron	400/12	1831	65-45-12	A536

Mechanical Seal
Multi spring balanced cartridge type with pumping ring double mechanical seal assembly with tungsten/ silicon carbide mechanical seal faces. The mechanical seal has an internal contained reservoir and is connected to an external reservoir.

OPTIONAL EXTRAS

Please contact us to discuss these options:

- Additional operational, mobility and safety extras such as: suction and discharge couplings, strainers, double skin fuel tanks and trailers. These can all be selected and fitted to our Premium Range (PR) pump units.
- Our PR build configuration uses Perkins diesel engines, however, alternative engine brands are available upon request.
- Other pump materials of construction are also available upon request: full 316 stainless steel, CD4MCU, chromium steel, SAF 2205 and SAF 2507.

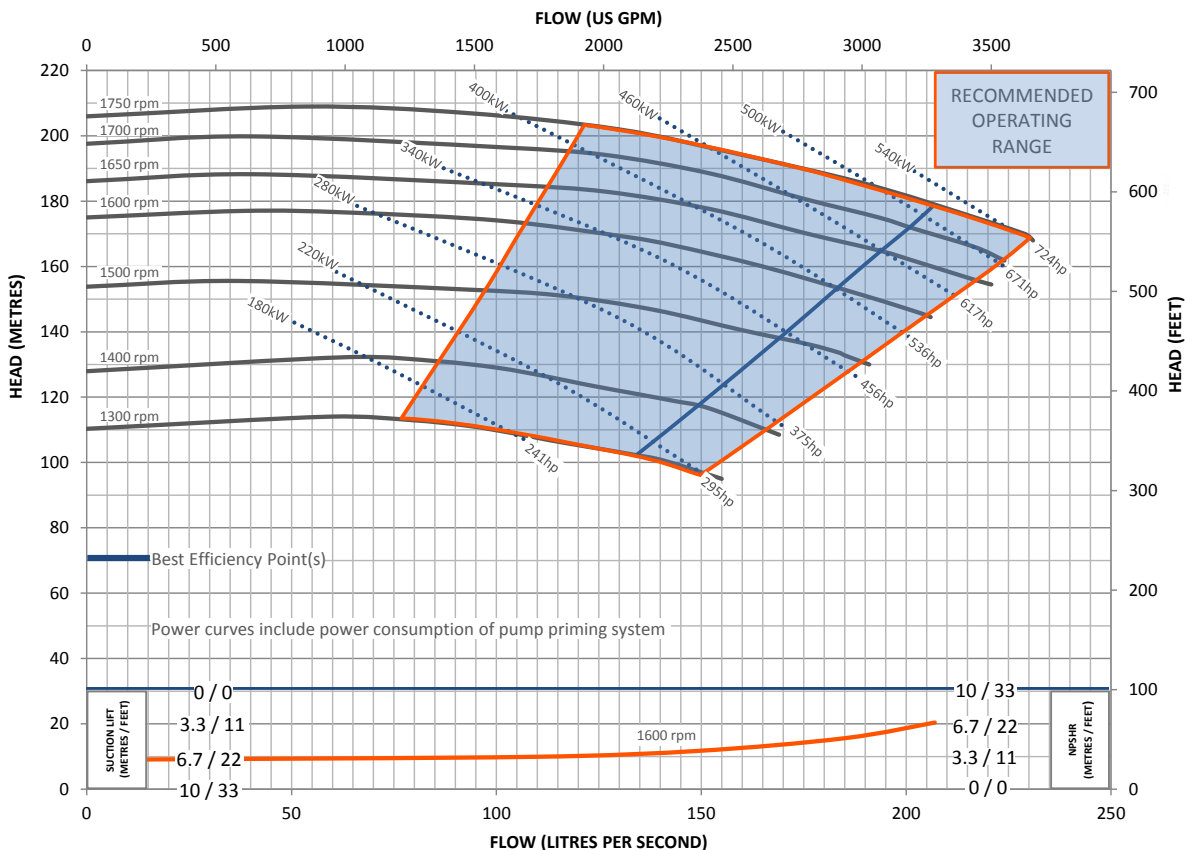

This pump and engine combination will produce up to 1,750 RPM of non-overload pump performance.

* Based on standard engine brake specific fuel consumption.

Final weight and dimensions will depend on completed specifications and options, subject to manufacturing tolerances. All the information in this document is substantially correct at the time of creation and may be altered at the manufacturer's sole discretion. Any quotes and related material provided supersedes the contents hereof.

TECHNICAL DATA

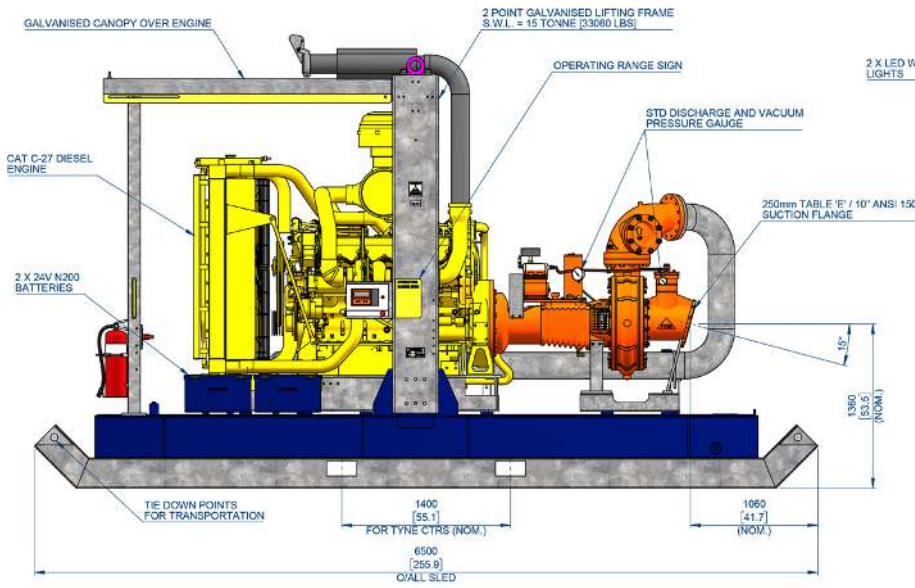

ELEVATION

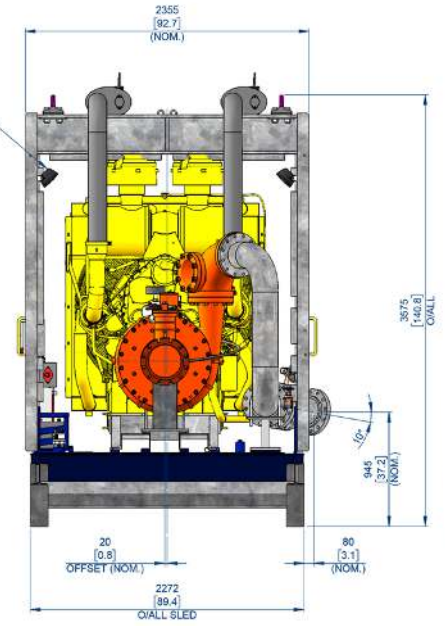

END ELEVATION

DRY: 10,735kg (23,660 lb)

WET: 13,480 kg (29,700 lb)

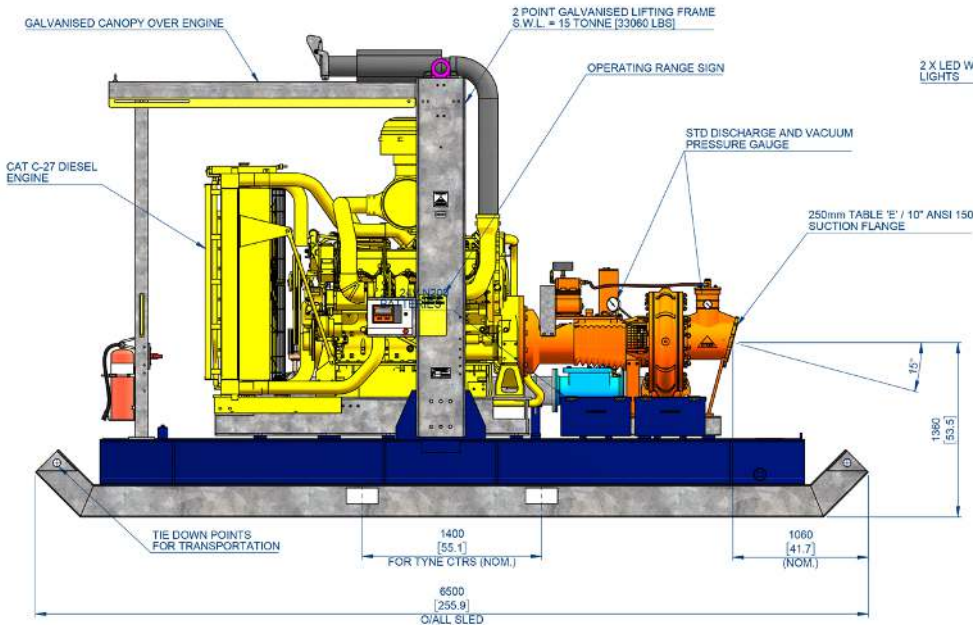

ELEVATION

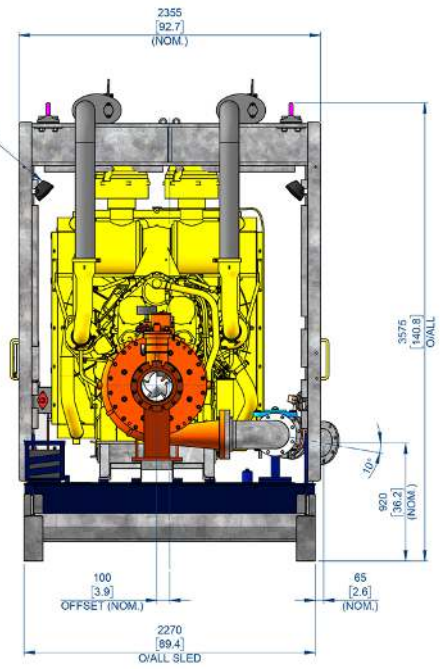

END ELEVATION

* Based on standard engine brake specific fuel consumption.

Final weight and dimensions will depend on completed specifications and options, subject to manufacturing tolerances. All the information in this document is substantially correct at the time of creation and may be altered at the manufacturer's sole discretion. Any quotes and related material provided supersedes the contents hereof.