



Built Tough

HIGH HEAD SR

HEAVY DUTY

Automatic self-priming single stage end suction pump

SOLIDS HANDLING

Large solids capacity while maintaining hydraulic efficiencies

CORROSION RESISTANT

Stainless steel 316 (CF8M) internals as standard.



Construction & Civil



Sewage & Waste Water



Quarries



Rental



Agriculture



Marine

DESIGN DETAILS

Auto self priming, centrifugal single stage, end suction, 3 vane semi open impeller

Suction Flange	200mm / 8"
Delivery Flange	200mm / 8"
Solids Handling	55mm / 2.16"
Maximum Head	125m / 410ft
Maximum Flow	270L/sec / 4,280 USgal/min
Engine Type	CAT-C13
Engine Adaptor	SAE #1
Shaft Diameter	75mm / 2.95"
Fuel Rate @ BEP 2,000rpm	71.6L/hr / 0.32 USgal/min *
Fuel Rate @ BEP 1,600rpm	37.0L/hr / 0.16 USgal/min *
Fuel Tank Capacity	1,400L / 370 USgal

MATERIALS OF CONSTRUCTION

STANDARDS	MATERIAL	AUSTRALIA		AMERICAS	
		GRADE	AS	GRADE	ASTM
Tee Piece	SG Iron	400/12	1831	65-45-12	A536
Pump Casing (Volute)	SG Iron	400/12	1831	65-45-12	A536
Front Wear Plate	Stainless	316/H6B	2074	CF8M	A351
Impeller	Stainless	316/H6B	2074	CF8M	A351
Rear Wear Plate	Stainless	316/H6B	2074	CF8M	A351
Pump Shaft	Stainless	431	2074	98b-431	A276
Bearing Bracket	SG Iron	400/12	1831	65-45-12	A536
Bearing Covers	SG Iron	400/12	1831	65-45-12	A536
Mechanical Seal	Multi-spring balanced cartridge type with pumping ring double mechanical seal assembly with tungsten/silicon carbide mechanical seal faces. The mechanical seal has an internal contained reservoir and is connected to an external reservoir.				

STANDARD RANGE (SR) INCLUSIONS

- Galvanised steel, dual point lifting frame.
- Manual diesel fuel fill (lockable).
- Pump and engine control panel with emergency stop as standard.
- Heavy duty battery, complete with battery box enclosure.
- Vacuum (suction inlet) and Pressure (discharge outlet) gauges.
- Pump operating range sign for optimum pump life and reliability.
- Galvanised steel sled, complete with tyne pockets and tie down points for transportation.

OPTIONAL EXTRAS

Please contact us to discuss these options:

- Additional operational, mobility and safety extras such as: suction and discharge couplings, strainers, battery isolators, heavy duty sleds and trailers. These can all be selected and fitted to our Standard Range (SR) pump units.
- Our SR build configuration uses Perkins diesel engines, however, alternative engine brands are available upon request.
- Other pump materials of construction are also available upon request: full 316 stainless steel, CD4MCU, chromium steel, SAF 2205 and SAF 2507.

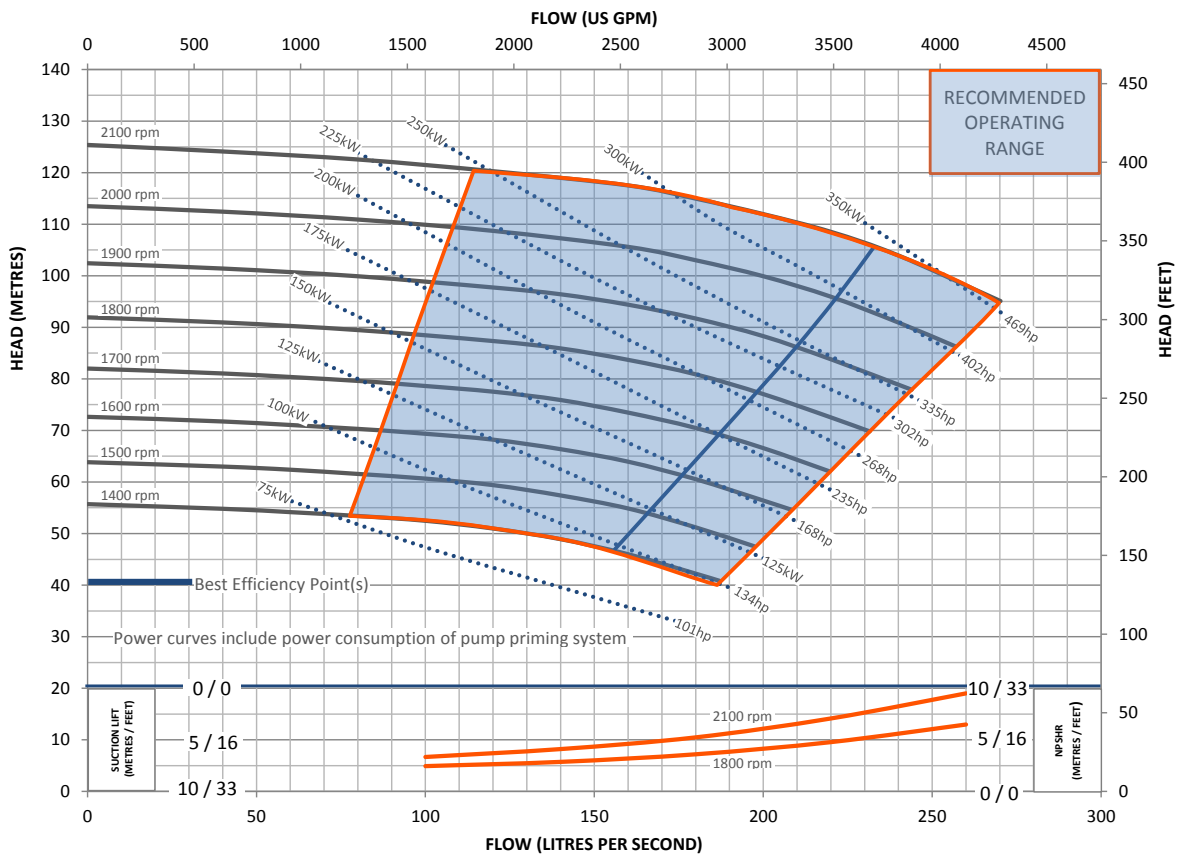

This pump and engine combination will produce up to 2,000 RPM of non-overload pump performance.

* Based on standard engine brake specific fuel consumption.

Final weight and dimensions will depend on completed specifications and options, subject to manufacturing tolerances. All the information in this document is substantially correct at the time of creation and may be altered at the manufacturer's sole discretion. Any quotes and related material provided supersedes the contents hereof.

TECHNICAL DATA

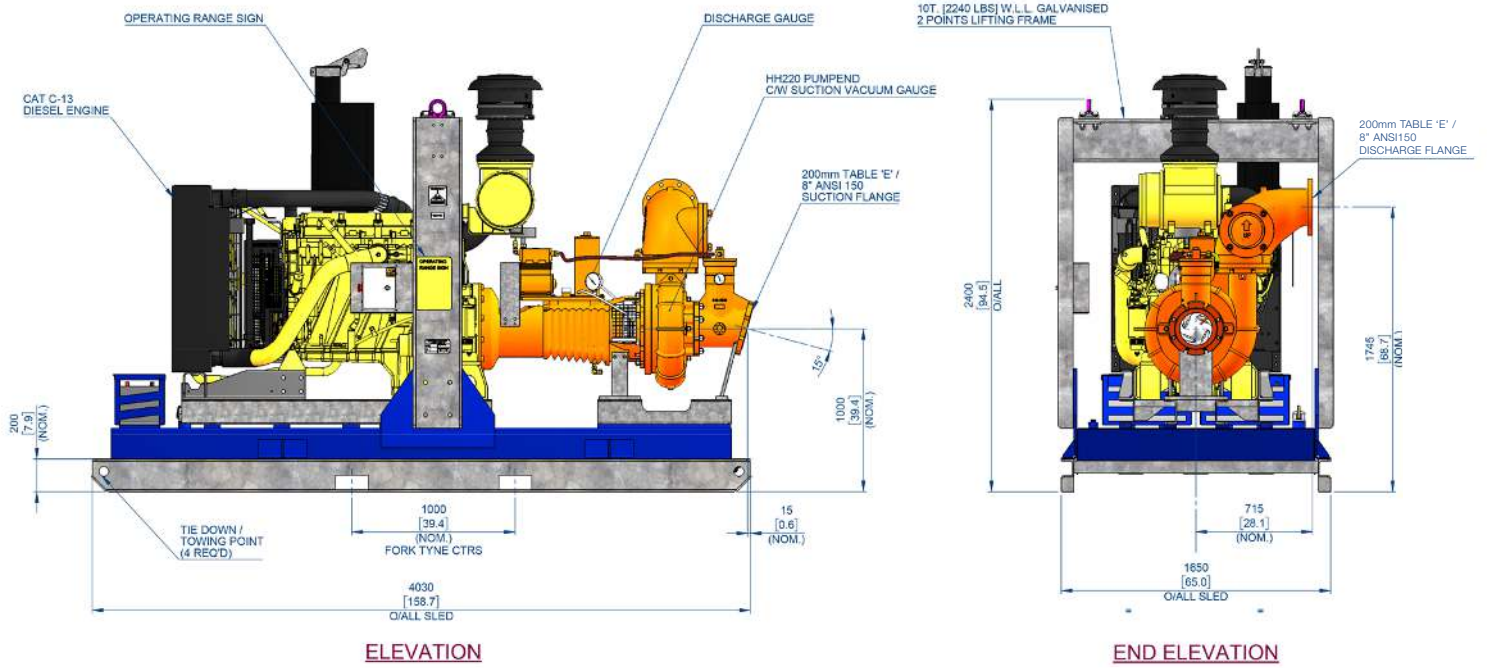

DRY: 4,390 kg (9,678 lb)

WET: 5,232 kg (11,534 lb)

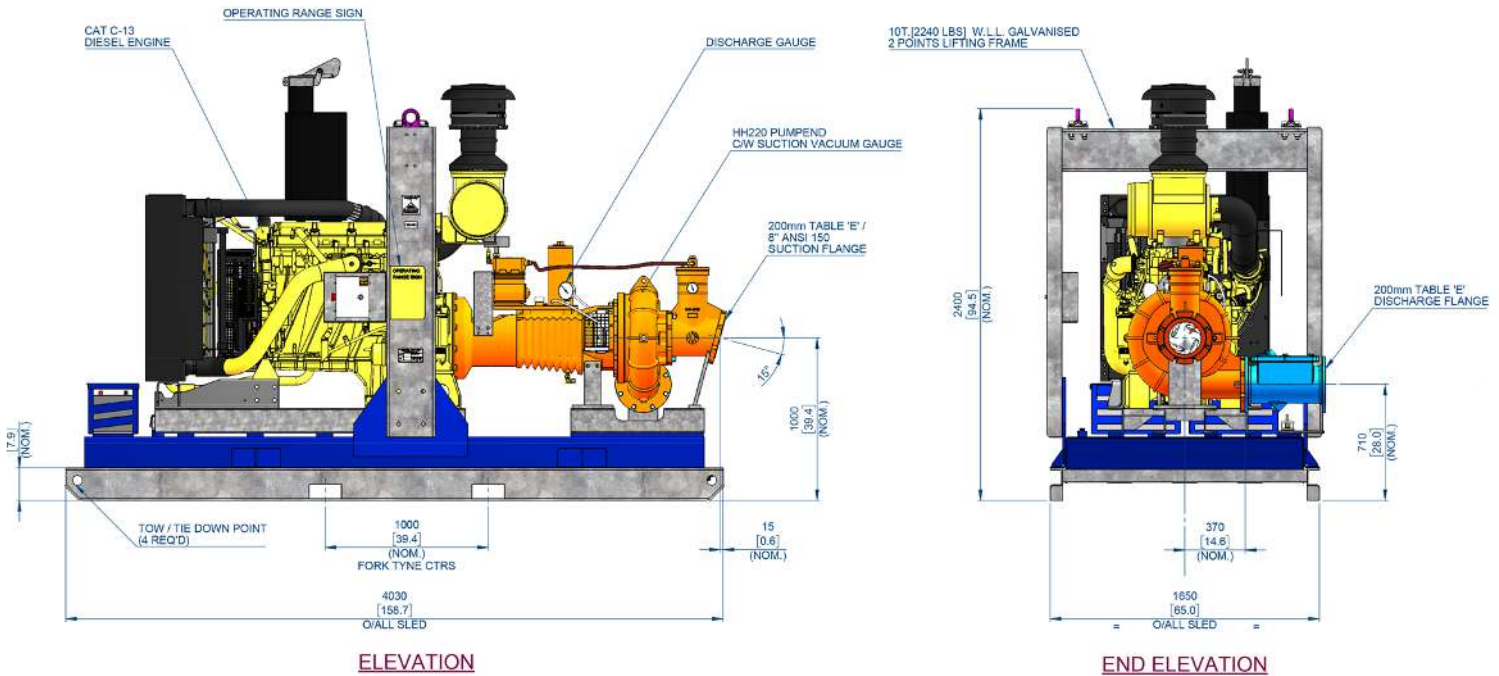

* Based on standard engine brake specific fuel consumption.

Final weight and dimensions will depend on completed specifications and options, subject to manufacturing tolerances. All the information in this document is substantially correct at the time of creation and may be altered at the manufacturer's sole discretion. Any quotes and related material provided supersedes the contents hereof.