



Built Tough

CONTRACTOR PUMP SR

HEAVY DUTY

Automatic self-priming single stage end suction pump

SOLIDS HANDLING

Large solids capacity while maintaining hydraulic efficiencies

CORROSION RESISTANT

Stainless steel 316 (CF8M) internals as standard.



Construction & Civil



Sewage & Waste Water



Quarries



Rental



Agriculture



Marine

DESIGN DETAILS

Auto self priming, centrifugal single stage, end suction, 2 vane semi open impeller

| | |
|--------------------------|-----------------------------|
| Suction Flange | 250mm / 10" |
| Delivery Flange | 250mm / 10" |
| Solids Handling | 60mm / 2.36" |
| Maximum Head | 75m / 246ft |
| Maximum Flow | 330L/sec / 5,231 USgal/min |
| Engine Type | Perkins 1106D-E70TA 186kW |
| Engine Adaptor | SAE #3 |
| Shaft Diameter | 50mm / 1.97" |
| Fuel Rate @ BEP 2,000rpm | N/A |
| Fuel Rate @ BEP 1,600rpm | 18.5L/hr / 0.08 USgal/min * |
| Fuel Tank Capacity | 900L / 198 USgal |

MATERIALS OF CONSTRUCTION

| STANDARDS | MATERIAL | AUSTRALIA | | AMERICAS | |
|----------------------|--|-----------|------|----------|------|
| | | GRADE | AS | GRADE | ASTM |
| Tee Piece | SG Iron | 400/12 | 1831 | 65-45-12 | A536 |
| Front Adaptor Plate | SG Iron | 400/12 | 1831 | 65-45-12 | A536 |
| Pump Casing (Volute) | SG Iron | 400/12 | 1831 | 65-45-12 | A536 |
| Front Wear Plate | Stainless | 316/H6B | 2074 | CF8M | A351 |
| Impeller | Stainless | 316/H6B | 2074 | CF8M | A351 |
| Rear Wear Plate | Stainless | 316/H6B | 2074 | CF8M | A351 |
| Rear Adaptor Plate | SG Iron | 400/12 | 1831 | 65-45-12 | A536 |
| Pump Shaft | Stainless | 431 | 2074 | 98b-431 | A276 |
| Bearing Bracket | SG Iron | 400/12 | 1831 | 65-45-12 | A536 |
| Bearing Covers | SG Iron | 400/12 | 1831 | 65-45-12 | A536 |
| Mechanical Seal | Multi spring balanced mechanical seal assembly with silicon carbide/silicon carbide mechanical seal faces in self-contained oil reservoir. | | | | |

STANDARD RANGE (SR) INCLUSIONS

- Galvanised steel, dual point lifting frame.
- Manual diesel fuel fill (lockable).
- Pump and engine control panel with emergency stop as standard.
- Heavy duty battery, complete with battery box enclosure.
- Vacuum (suction inlet) and Pressure (discharge outlet) gauges.
- Pump operating range sign for optimum pump life and reliability.
- Galvanised steel sled, complete with tyne pockets and tie down points for transportation.

OPTIONAL EXTRAS

Please contact us to discuss these options:

- Additional operational, mobility and safety extras such as: suction and discharge couplings, strainers, battery isolators, heavy duty sleds and trailers. These can all be selected and fitted to our Standard Range (SR) pump units.
- Our SR build configuration uses Perkins diesel engines, however, alternative engine brands are available upon request.
- Other pump materials of construction are also available upon request: full 316 stainless steel, CD4MCU, chromium steel, SAF 2205 and SAF 2507.

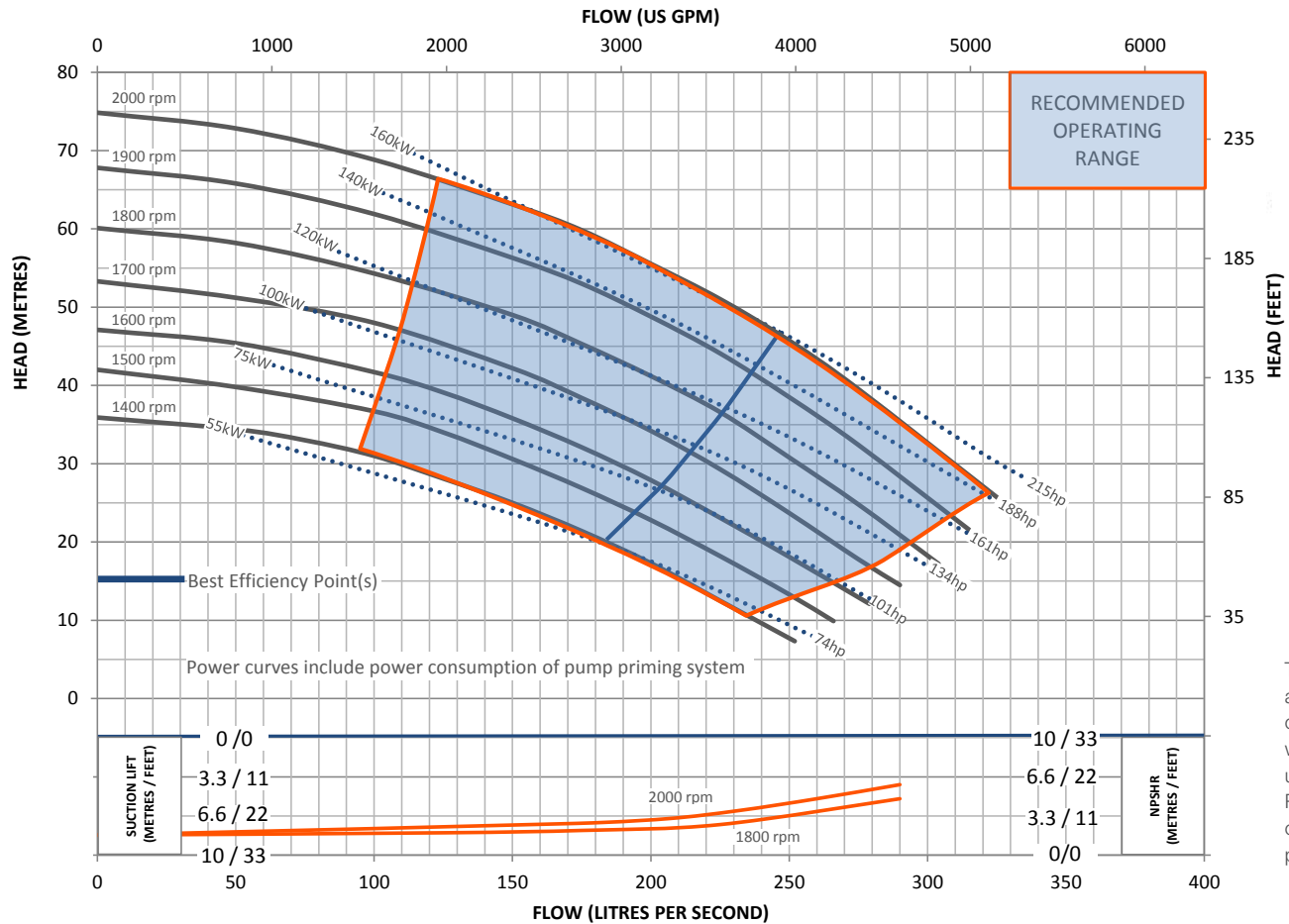

This pump and engine combination will produce up to 2,000 RPM of non-overload pump performance.

* Based on standard engine brake specific fuel consumption.

Final weight and dimensions will depend on completed specifications and options, subject to manufacturing tolerances. All the information in this document is substantially correct at the time of creation and may be altered at the manufacturer's sole discretion. Any quotes and related material provided supersedes the contents hereof.

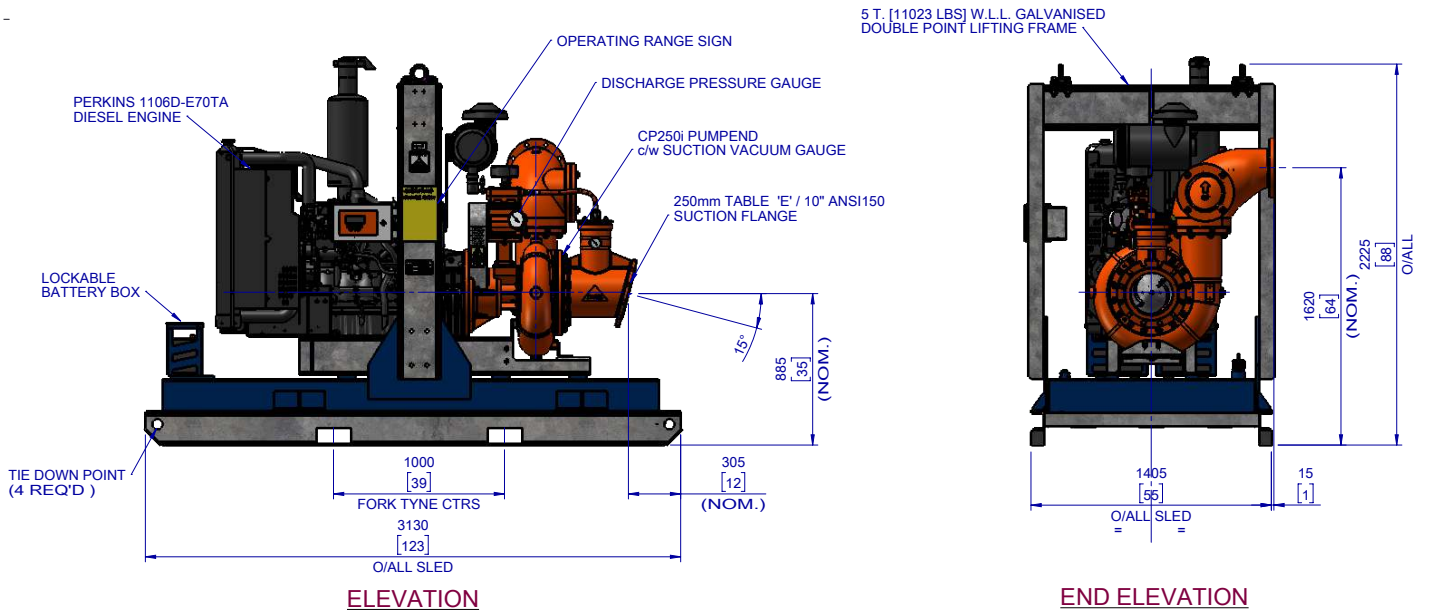

DRY: 2,359 kg (5,200 lb)

WET: 3,108 kg (6,852 lb)

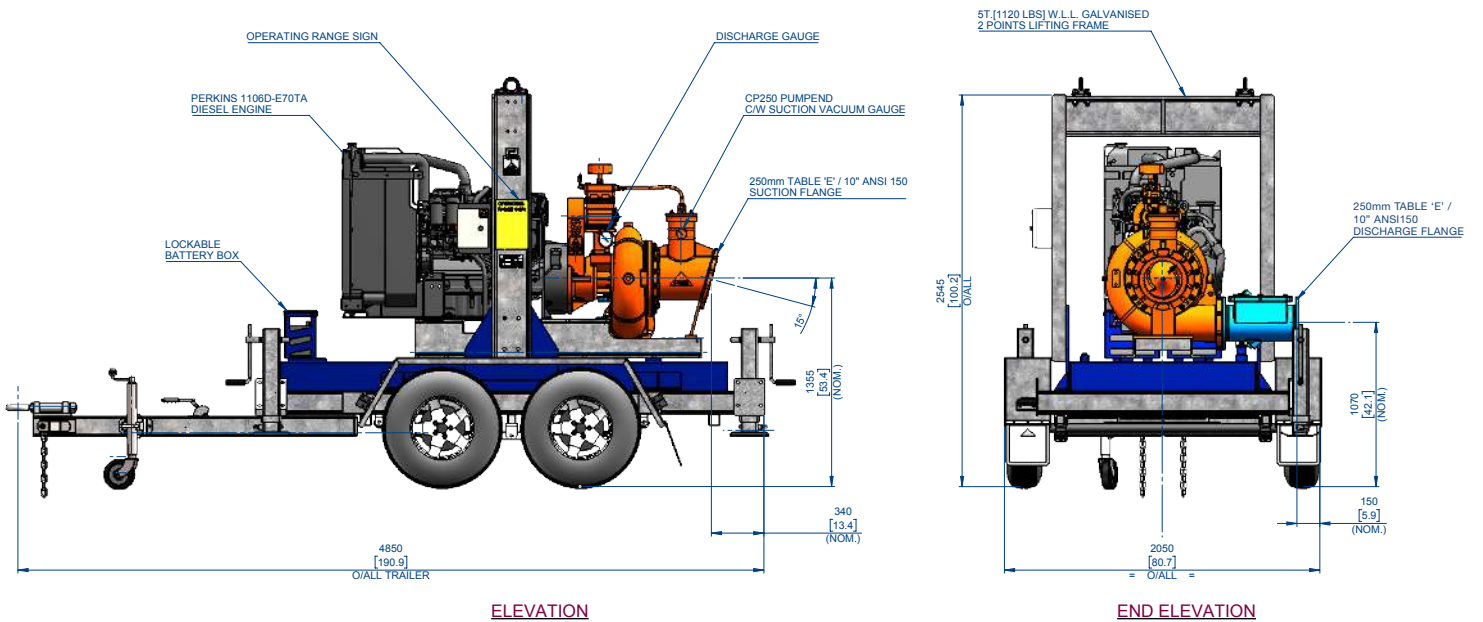

DRY: 2,525 kg (5,566 lb)

WET: 3,270 kg (7,209 lb)

* Based on standard engine brake specific fuel consumption.

Final weight and dimensions will depend on completed specifications and options, subject to manufacturing tolerances. All the information in this document is substantially correct at the time of creation and may be altered at the manufacturer's sole discretion. Any quotes and related material provided supersedes the contents hereof.